

- X-ray inspection for packaged food or non-food products
- Detects high density materials like metal, ceramic, stone or plastic
- Easy operation with autocalibration and clearly arranged functions on 17" touchscreen
- XIA software for instant analysis and detection with high accuracy and reliability
- Quick release conveyor belt for easy cleaning and maintenance



- Real time detection with coloured contamination analysis
- Masking functions
- Auto-storing of inspection data with time and date stamp
- User-friendly menus for easy operation
- USB and Ethernet
- Quick release conveyor belt
- Easy maintenance and cleaning
- Built-in remote maintenance
- 24 hours non-stop operation
- TÜV-approved: reliable german safety standard (optional TÜV certificate)



Large touch screen and clear menus ensure easy handling in daily business.

Scope of Delivery:

- Xray Scanner with image processing software XIA
- Complete protection against radiation and PILZ safety circuit
- Certified test cards with soda lime glass, ceramics, steel spheres in various diameters

Accessories & Extras:

- Separate conveyor with automatic reject
- Radiation counter
- 21 CFR Part 111 compliance
- BRC compliance kit



XRAY SHARK® XD38 with air pressure reject system.

Function:

The XD38-L1 and XD38-H1 are particularly suitable for packaged food or non-food products, for example in plastic packaging, jars, cartons and even metal foil or metal cans. It detects unwanted foreign objects such as metal, stones, ceramic or plastic with high density in the product.

The hygienic design allows for easy cleaning and maintenance of the device - no tools required. This makes the XD38-L1 and XD38-H1 particularly suitable for all companies and industries that have to ensure high hygiene standards (also available with IP66).



XRAY SHARK® XD38 with air pressure reject system.

Applications:

Inspection of packaged food and non-food products in

- cardboard or plastic boxes
- plastic or metal foils
- pouch bags
- jars or metal cans
- etc.

Industries:

- Food and non-food
- Pharma
- Hygiene and Cosmetics
- etc.

Specifications:

Model (till 04-2020)	XD38-L1 (XBD20+)	XD38-H1 (XBD40)
X-ray source	Single beam x-ray generator with max. 60kV (50W), variable in voltage + current	Single beam x-ray generator with max. 80kV (480W), variable in voltage + current
Radiation leakage	1 µSv/h or less	3 µSv/h or less
Safety	at 10 cm outside cabinet surfaces using all safety devices	
Safety	X-ray protective curtains (lead-free) - quickly detachable, magnetic safety switches at cabinet doors and tunnel hatches, emergency stop push button, emergency stop in/out interfaces to safety circuits of production line, X-ray off key switch, PILZ safety circuit	
X-ray detector	Low noise 408 mm line scan CCD, diode pitch 0.8 mm (0.4 mm optional)	
X-ray view	1x top down	
Cooling	Highly efficient, silent DC filter fans	
Housing finish	Stainless steel grade AISI 304 / DIN EN 1.4301 (X5CrNi18-10)	
Enclosure rating	IP54 (according to IEC 60529), optional in IP66	
	PU light blue, food grade	PU white, food grade
Conveyor speed	Conveyor speed by product, 0.05 to 0.98 m/sec (7 fixed speed steps)	
Belt width	400 mm (net width 380 mm)	
Max. product dimensions (width x height)	340x60 mm / 300x100 mm / 250x160 mm / 200x200 mm	
Max. product weight	7 kg	
Available reject method	Second conveyor with Air jet or transversal pusher	
Product Memory	255 different product set-ups	
Display	17" Color-TFT capacitive touchscreen	
Inspection features	Autocalibration, auto adaption to density distribution, density, hard contrast, soft contrast, masking technology, SuperContrast, SizeFilter, AutoEdge masking, images AutoSave/Load, multi segment inspection, metal can and foil inspection, fill quantity, generator energy by product, password protection	
In/Outputs	Programmable outputs (contamination, ready, emergency stop) Programmable inputs (emergency stop, wake up, optional control signals)	
Data transfer and reporting	Ethernet for remote support via internet, USB for external keyboard/ mouse/ memory stick	
Max. weight	0.5 t	
Electrical mains connection	1ph, 230 VAC +/- 10%, 50/60 Hz, full operation	
	0.5 kW	1.0 kW
Compressed air supply	Without reject system 0 MPa (0 bar / 0 psi) With optional reject system minimum 0.4 MPa (4 bar / 58 psi)	
Environmental	0°C to +30°C / 32°F to 86°F, with relative humidity max 90%, non-condensing Option: additional external cooling devices to extend the temperature range	
Conformity	CE, compliant to German x-ray regulations, specific adaptation for other countries	

All information is based on standard devices. Differences depending on the application to be expected.

Easy Cleaning:



Open side panel.



Remove curtains.



Release the conveyor belt.



Remove conveyor belt.

Dimensions:

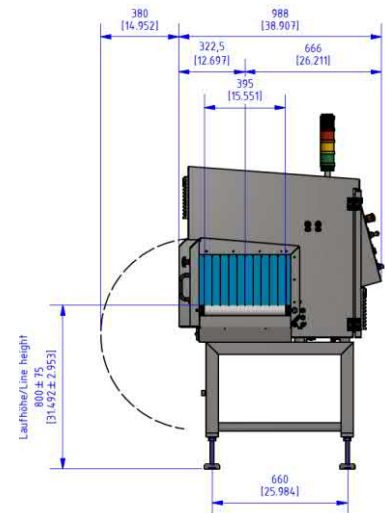
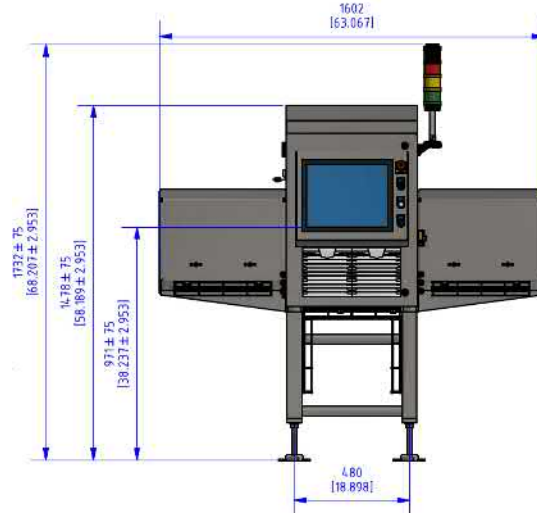

Max. product height versus max. product width, due to the shape of x-ray beam fan

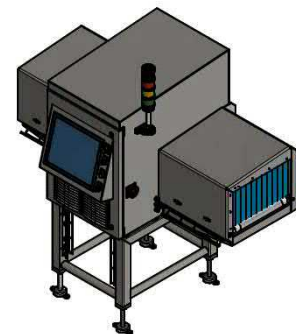
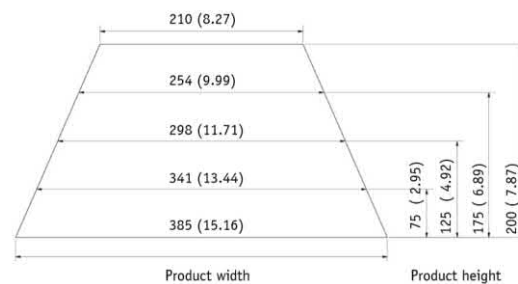

CASSEL quality:

As a premier manufacturer, CASSEL is committed to the highest quality standards. For more than 25 years, our goal has been to ensure the uncompromising quality of your products. We supply customers world-wide in various industries, including food, plastics, pharmaceuticals, textiles, lumber and mining.

Contact us:

CASSEL Messtechnik GmbH
In der Dehne 10
37127 Dransfeld
phone: +49 (0)5502 911 50
fax: +49 (0)5502 911 532
info@cassel-inspection.com

